

Rideworks fit angular contact bearings in our BB's of this type, angular contact (A/C) bearings require some preload,

**Use the provided light wave washer ensure it is completely flattened against seal face after the cranks are installed**

Install Tool:

Enduro Torq Tite

- For Shimano style 24mm Cranks
- Threaded bottom bracket shells, it is critical that the shell's threads have been properly chased and the shell faced.
- Grease threads well before install, use high quality grease.
- For titanium BB shells, anti-sieze grease is recommended.
- Tighten cup to 35Nm
- Support NDS seal when pushing through crank spindle to prevent seal popping out.

To remove.

Rotate drive side cup clockwise  
And non drive side cup anti clockwise  
Remove cups and middle tube out

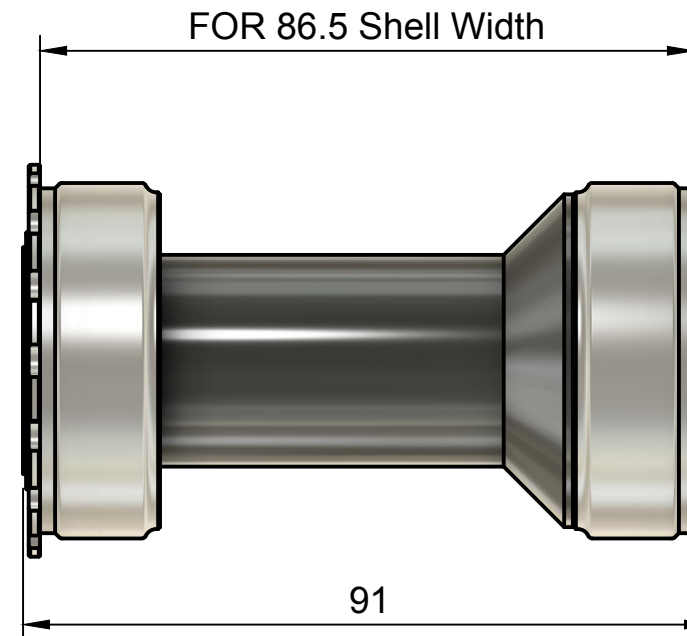

NO SPACERS REQUIRED FOR SHELL WIDTH ABOVE WHEN USING THE RESPECTIVE CRANKS

Dept.	Technical reference	Created by <b>Rideworks</b>	2017	Approved by
		Document type	Document status	
		Title <b>T47 24i 86.5 Shell</b>	DWG No.	
		Rev.	Date of issue	Sheet <b>1/1</b>