

A
B
C
D
E
F

Parts List				
Item	Qty	Part Number	Description	Material
1	1	Top Cup		Aluminum
2	1	Top bearing 36/45		Steel
3	1	Shim		Aluminum
4	1	Top SEAL		Rubber
5	1	Top Cover		Aluminum
6	1	Bottom Cup		Aluminum
7	1	Crown Race V7.0B		Aluminum
8	1	BOTTOM SEAL		Rubber
9	1	Bottom Bearing 45/45		Steel

After prepping the head tube face and ream (if required) and pressing in the cups

Apply some grease to the O ring inside the top cover (ITEM 5) also grease the 2 rubbers (ITEMS 8 and 4.)

Slide crown race ITEM 7 over fork and place bearing on top of crown race.

Place top bearing and shim in top cup

Insert fork from the bottom

Install shim over steerer and press into the bearing

Place top top cover over steerer and slide down

STACK HEIGHT Top 7.1mm Bottom 14.6mm

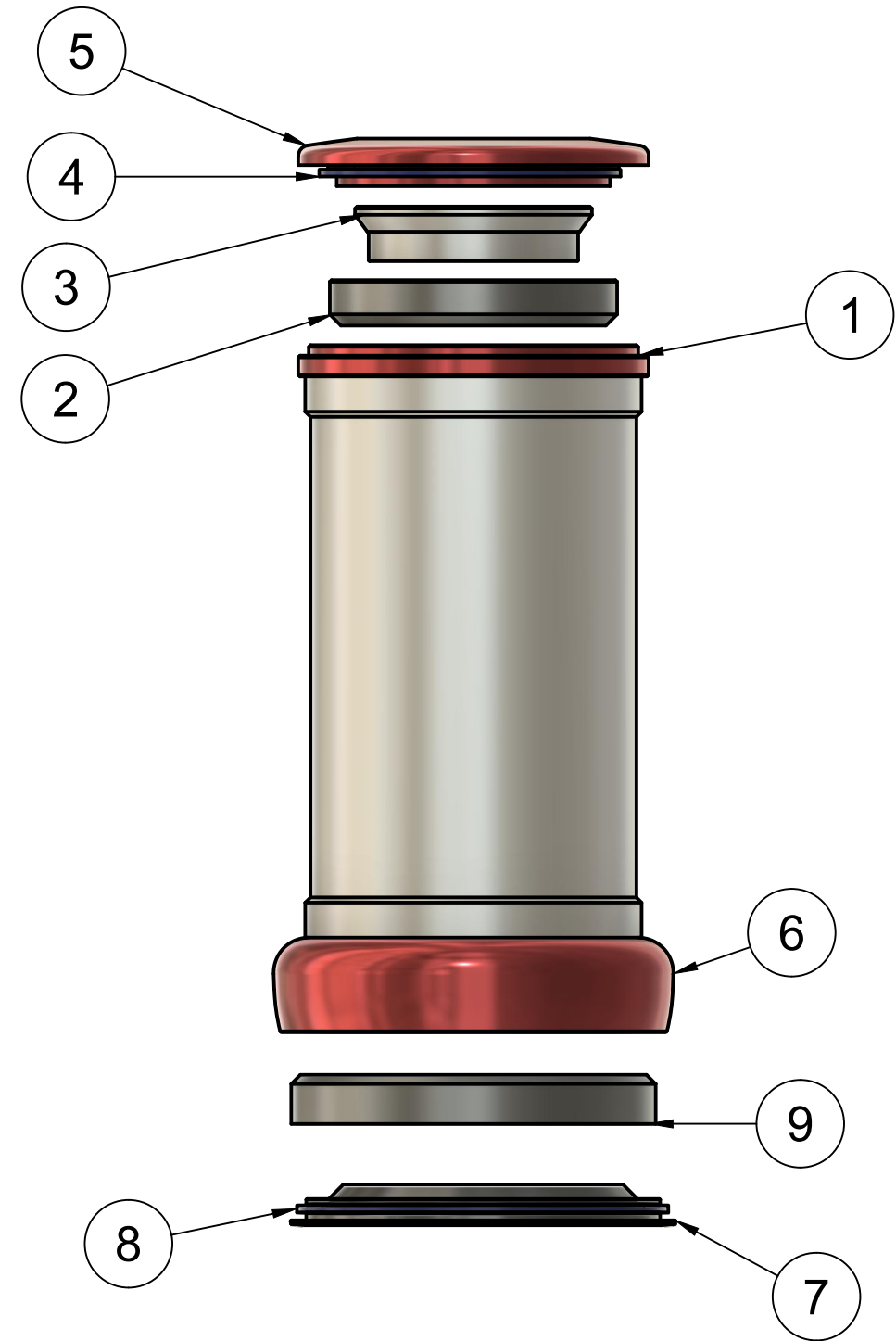

Dept.	Technical reference	Created by Rideworks 04/10/2018	Approved by
		Document type	Document status
		Title ZS44 EC44 Headset	DWG No.
Rev.	Date of issue	Sheet 1/1	